

## Tension Compression Load Cells

### FEATURES

- Capacities 50–1000 kg
- Nickel-plated alloy steel (615) or stainless steel (616) construction
- Protection: Model 616—IP66; Model 615—IP67
- For use in tension or compression
- 6-wire (sense) circuit
- Output standardised to  $\pm 0.1\%$

### APPLICATIONS

- Hopper (tank weighing)
- Hybrid scales
- Belt weighing
- Lever arm conversions
- Material testing machines
- Vibration filling equipment
- Dynamometers

### DESCRIPTION

The Models 615 and 616 are tension compression load cells which share the same dimensions. Humidity-resistant coating and shielded cables enable these load cells to be used in harsh environments while maintaining their operating specifications.

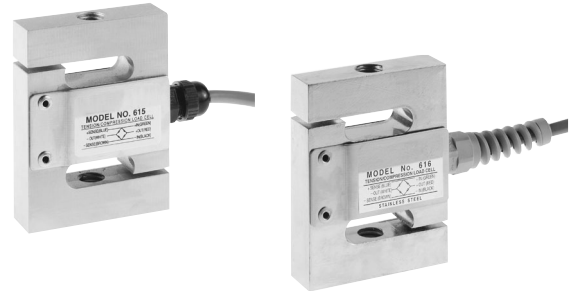

The additional sense wires compensate for changes in lead resistance due to temperature change and/or cable extension.

Ideally suited for lever conversions, hanging scales, force measurement and a wide range of other industrial applications.

The Model 616 is made from stainless steel and has bonded covers for additional protection (except 50 kg). The Model 615 is an alternative, lower cost version made from alloy steel with riveted covers.

### OUTLINE DIMENSIONS in millimeters

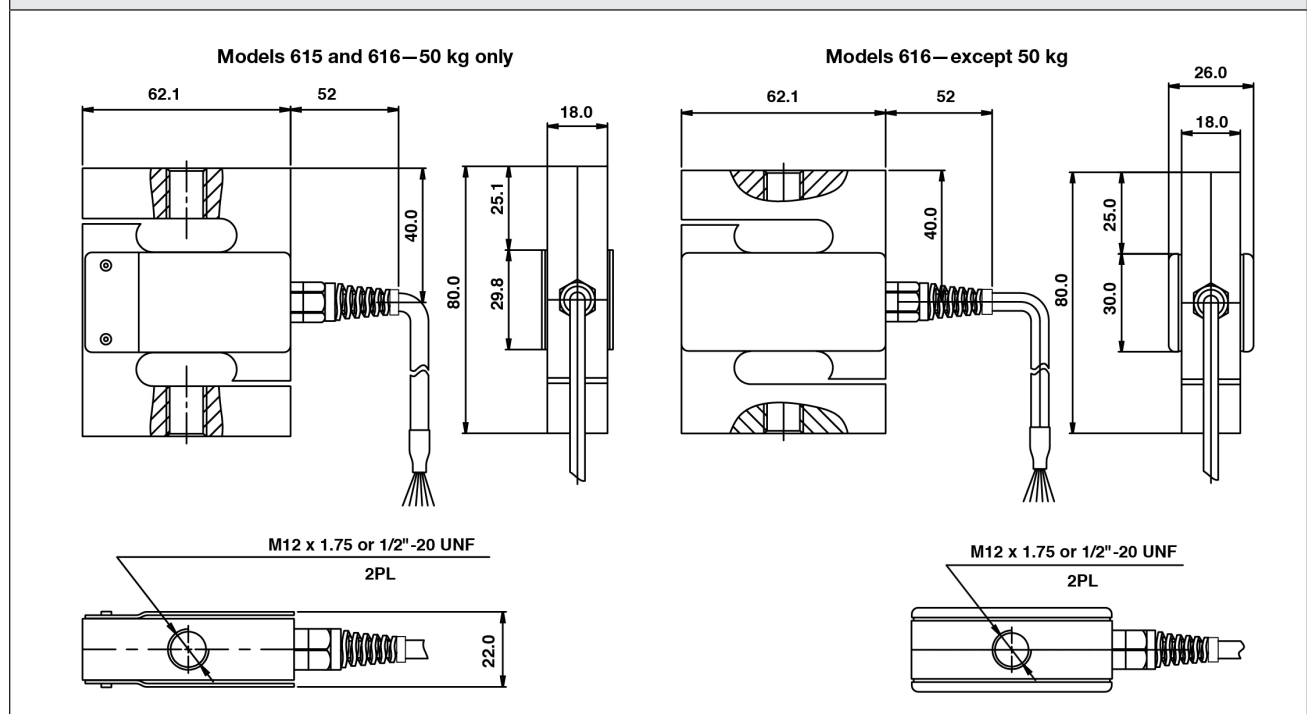

Tension Compression Load Cells

SPECIFICATIONS			
PARAMETER	VALUE		UNIT
Accuracy class	Non-Approved	G	
Maximum no. of intervals (n)	1000	3000	
Rated capacity—R.C. (Emax)	50, 100, 150, 200, 300, 500, 750, 1000*		kg
Rated output—R.O.	2.0		mV/V
Rated output tolerance	0.002		±mV/V
Zero balance	0.2		±mV/V
Zero return, 30 min.	0.05	0.017	±% of applied load
Total error (per OIML R60)	0.05	0.02	±% of rated output
Temperature effect on zero	0.01	0.004	±% of rated output/°C
Temperature effect on output	0.003	0.0012	±% of load/°C
Temperature range, compensated	-10 to +40		°C
Temperature range, safe	-30 to +70		°C
Maximum safe central overload	150		% of R.C.
Ultimate central overload	300		% of R.C.
Excitation, recommended	10		VDC or VAC RMS
Excitation, maximum	15		VDC or VAC RMS
Input impedance	400±20		Ω
Output impedance	350±3		Ω
Insulation resistance	>2000		MΩ
Cable length	3.0		m
Cable type	6-wire, PVC, braid shield		Standard
Construction	Model 615—alloy steel; Model 616—stainless steel		
Environmental protection	Model 616—IP66; Model 615—IP67		

All specifications are subject to change without notice.

**Wiring Schematic Diagram**  
 (Balanced bridge configuration)

