

### Single-Ended Beam Load Cell

#### FEATURES

- Capacities: 500–5000 kg, 1k–10k lbs.
- Low profile construction
- Certified to OIML R-60, 3000d and NTEP class III, 3000 divisions
- Sealing: IP67 (DIN 40.050)
- Nickel-plated alloy steel construction
- Threaded load hole
- **Optional**
  - FM certified for use in potentially explosive atmospheres



#### APPLICATIONS

- Floor scales
- Tank weighing
- Bin and hopper weighing

This product is suitable for small and medium platform scales, overhead track scales, hopper scales, and process weighing applications.

Reliable sealing is ensured by the proprietary TRANSEAL potting compound and additional mechanical protection of the strain gage area.

#### DESCRIPTION

Model 5123 is a low profile single-ended shear beam type load cell made from nickel-plated tool steel.

Ease of installation is made possible through the use of a partially threaded hole to accept levelling feet, load buttons, or loading cables.

#### OUTLINE DIMENSIONS in inches [millimeters]

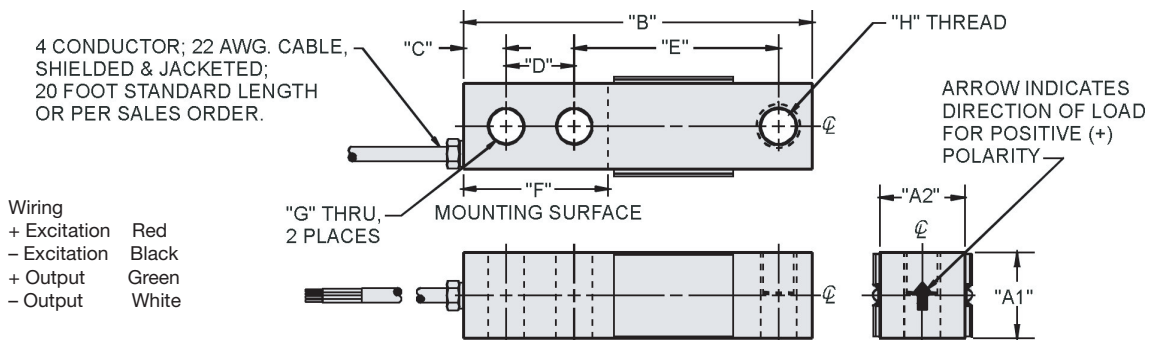

CAPACITY	A <sub>1</sub>	A <sub>2</sub>	B	C	D	E	F	G	H	DEFLECTION	WEIGHT
1k–4k lbs.	1.25	1.25	5.12	0.62	1.00	3.00	2.25	0.53	1/2-20 UNF-2B, Ø0.53 x 0.62 DP C'BORE	0.017 - 0.025	4.0
5k–10k lbs.	1.50	1.50	6.75	0.75	1.50	3.75	3.00	0.78	3/4-16 UNF-2B, Ø0.78 x 0.75 DP C'BORE	0.025 - 0.035	6.5
[500 kg–2T]	[32.0]	[32.0]	[130.0]	[16.0]	[25.0]	[76.0]	[57.0]	[13.0]	M12 x 1.75-6H, Ø13 x 15 DP C'BORE	[0.432 - 0.635]	[1.8]
[3T–5T]	[38.0]	[38.0]	[171.0]	[19.0]	[38.0]	[95.0]	[76.0]	[20.7]	M20 x 2.5-6H, Ø20.5 x 19 DP C'BORE	[0.635 - 0.889]	[2.9]

Capacities are in pounds [kg/T]. Deflection is ±10%. Certified drawings are available.

### Single-Ended Beam Load Cell

SPECIFICATIONS				
PARAMETER	VALUE			UNIT
Standard capacities ( $E_{max}$ )	500, 1000, 2000, 5000 <sup>(1)</sup>			kg
Standard capacities ( $E_{max}$ )	1k, 2.5k, 4k, 5k, 10k <sup>(1)</sup>			lbs.
Accuracy class according to OIML R-60 /NTEP	NTEP III	Non-Approved	C3	
Max. no. of verification intervals	3000		3000	
Min. verification interval ( $V_{min}=E_{max}/Y$ )			$E_{max}/6000$	
Min. verification interval, type MR			$E_{max}/10000$	
Rated output (=S)	3			mV/V
Rated output tolerance	0.0075			±mV/V
Zero balance	1.0			±% FSO
Combined error	0.0200	0.050	0.023	±% FSO
Minimum dead load output return	0.0250	0.050	0.017	±% FSO
Minimum dead load output return, type MIB			0.0063	±% FSO
Non-repeatability	0.0100	0.01	0.01	±% FSO
Creep error (30 minutes)		0.060	0.025	±% FSO
Temp. effect on min. dead load output	(0.0008)	0.0250	0.0120	±% FSO/5°C (°F)
Temp. effect on min. dead load output, type MR			0.0070	±% FSO/5°C
Temperature effect on sensitivity	(0.0010)	0.0250	0.0088	±% FSO/5°C (°F)
Minimum dead load	0			% $E_{max}$
Maximum safe overload	150			% $E_{max}$
Ultimate overload	300			% $E_{max}$
Maximum safe side load	100			% $E_{max}$
Deflection at $E_{max}$	0.4 / 0.8 / 1.0 / 1.1 – kg 0.4 / 0.8 / 1.0 / 0.9 / 1.1 – lbs.			mm
Excitation voltage	5 to 12			V
Maximum excitation voltage	15			V
Input resistance	350±7			Ω
Output resistance	352±3			Ω
Insulation resistance	>1000			MΩ
Compensated temperature range	-10 to +40			°C
Operating temperature range	-18 to +65			°C
Storage temperature range	-50 to +85			°C
Element material	Nickel-plated alloy steel			
Sealing (DIN 40.050 / EN 60.529)	IP67			
Recommended torque on fixation bolts	0.5–2T and 1k–4k lbs.: 136 5k lbs. and 5T and over: 205			N*m

<sup>(1)</sup> 5T and 10k lbs. are not approved by OIML

FSO—Full Scale Output

Correct mounting of the load cell is essential to ensure optimum performance. Further information is available on request.

All specifications are subject to change without notice

### CERTIFICATION MARKINGS

#### FM Approval markings (USA and Canada)

IS Class I, II, III, Division 1, Groups A, B, C, D, E, F and G;

NI Class I, Division 2, Groups A, B, C, and D;

DIP Class II, III, Division 2, Groups F and G;

T4;

Ta = -25°C to +40°C;