

Double-Ended Shear Beam Load Cell

FEATURES

- Rated capacities of 5,000 to 100,000 pounds, 2.3 to 45 metric tonnes
- High quality alloy tool steel construction
- Nickel plated for outstanding corrosion resistance
- Replacement for RTI model 5103 (EZM1)
- Integral conduit adaptor
- *Sensorgage*™ sealed to IP67 standards
- Factory Mutual System Approved for Classes I, II, III; Divisions 1 and 2; Groups A through G. Also, non-incendive ratings (No barriers!)
- **Optional**
 - EDOC option available; product appearance will differ from the photograph due to coating

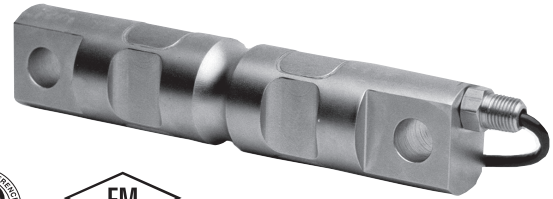

APPLICATIONS

- Tank, bin, and silo weighing
- Railroad track scales
- Truck scales

DESCRIPTION

The Model 60058 is a mid to high capacity nickel-plated alloy steel, double-ended shear beam load cell.

This product is designed for use in industrial and outdoor environments. Nickel plated steel construction limits corrosion from outdoor use. The IP67 sealing makes it suitable for applications that are subject to high-pressure wash down. Tank weighing is made simple when this load cell is combined with the EZ mount mounting hardware it was designed for. Its high accuracy and availability in high capacities make it ideal for certified truck and rail scales.

This load cell is rated intrinsically safe by the Factory Mutual System (FM); making it suitable for use in potentially explosive environments. This load cell is certified for Legal For Trade applications by the American NTEP standards.

OUTLINE DIMENSIONS in inches (millimeters)

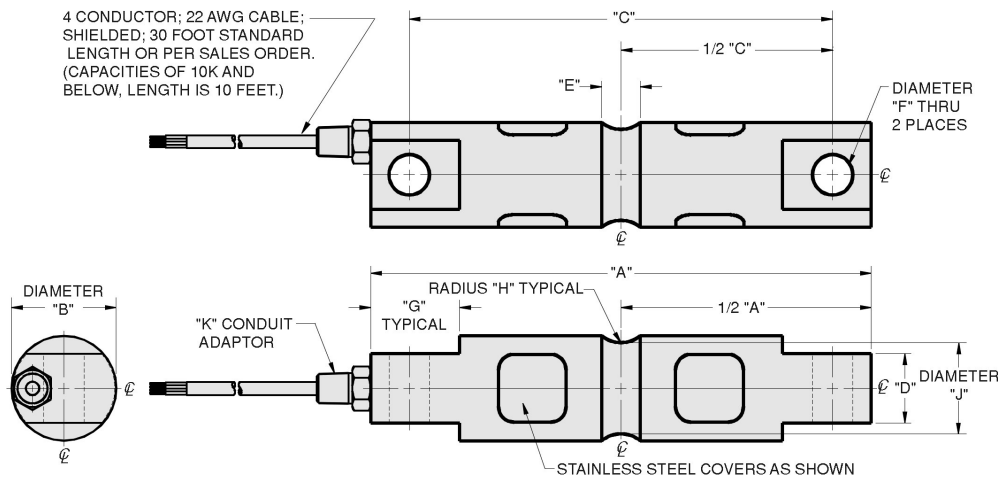

CAPACITY	A	B	C	D	E	F	G	H	J	K-THREAD
5k-20k	8.12	1.70	6.88	1.13	0.63	0.65	1.44	0.50	1.48	1/4-18 NPT
30k-60k	10.25	2.97	8.50	2.38	0.95	1.06	1.94	1.00	2.73	1/2-14 NPT
100k	11.25	3.50	9.50	2.50	1.25	1.06	1.88	1.50	3.24	1/2-14 NPT
(2.3-9 t)	(206.2)	(43.2)	(174.8)	(28.7)	(16.0)	(16.5)	(36.6)	(12.7)	(37.6)	1/4-18 NPT
(13.6-27 t)	(260.4)	(75.4)	(215.9)	(60.5)	(24.1)	(26.9)	(49.3)	(25.4)	(69.3)	1/2-14 NPT
(45 t)	(285.8)	(88.9)	(241.3)	(63.5)	(31.8)	(26.9)	(47.8)	(38.1)	(82.3)	1/2-14 NPT

Capacities are in pounds (kg/t). Above dimensions apply to non-EDOC-coated load cells.

Double-Ended Shear Beam Load Cell

SPECIFICATIONS				
PARAMETER	VALUE			UNIT
Rated capacity—R.C. (E _{max})	5k, 10k, 20k, 30k, 40k, 50k, 60k, 100k 2.3, 4.5, 9.0, 13.6, 18.0, 23.0, 27.0, 45.0			lbs t
NTEP/OIML accuracy class	NTEP III	NTEP III L	Standard	
Maximum no. of intervals (n)	5000 multiple	10000 multiple		
Y = E _{max} /V _{min}	See NTEP cert. 97-042A1			Maximum available
Rated output—R.O.	3.0			mV/V
Rated output tolerance	0.25			±% mV/V
Zero balance	1.0			±% FSO
Combined error	0.02	0.02	0.03	±% FSO
Non-repeatability	0.01	0.01	0.01	±% FSO
Creep error (20 minutes)	0.030	0.030	0.03	±% FSO
Temperature effect on zero	0.0015	0.0010	0.0015	±% FSO/°F
Temperature effect on output	0.0008	0.0008	0.0008	±% of load/°F
Compensated temperature range	14 to 104 (-10 to 40)			°F (°C)
Operating temperature range	0 to 150 (-18 to 65)			°F (°C)
Storage temperature range	-60 to 185 (-50 to 85)			°F (°C)
Safe sideload	100			% of R.C.
Maximum safe central overload	150			% of R.C.
Ultimate central overload	300			% of R.C.
Excitation, recommended	10			VDC or VAC RMS
Excitation, maximum	15			VDC or VAC RMS
Input impedance	686–714			Ω
Output impedance	699–707			Ω
Insulation resistance at 50 VDC	>1000			MΩ
Material	Nickel-plated alloy tool steel			
Environmental protection	IP67			

FSO— Full Scale Output

R.C.— Rated Capacity

All specifications subject to change without notice.

CERTIFICATION MARKINGS

FM Approval markings (USA and Canada)

IS Class I, II, III, Division 1,

Groups A, B, C, D, E, F and G; T4

Ta = -25°C to +40°C