

Rocker Column Load Cell

FEATURES

- Capacities: 30T and 40T
- Self-restoring rocker column
- High performance compact design
- Environmentally sealed, IP66/IP68 (5 bar)
- Certificate: OIML R60 and NTEP Class III; 10,000d approved.
- Current calibration output ensures easy and accurate parallel connection of multiple load cells
- Anti-rotation pin

APPLICATIONS

- Weighbridges
- Silo and hopper weighing
- Process weighing

DESCRIPTION

Model 116 is a high-capacity single-column load cell, designed around a nickel-plated, alloy steel element. It is environmentally sealed and the use of redundant O-rings and high-grade potting material provide excellent ingress protection.



Model 116 is suitable for all heavy weighing applications and provides the user with excellent overall value.

OUTLINE DIMENSIONS in millimeters [inches]

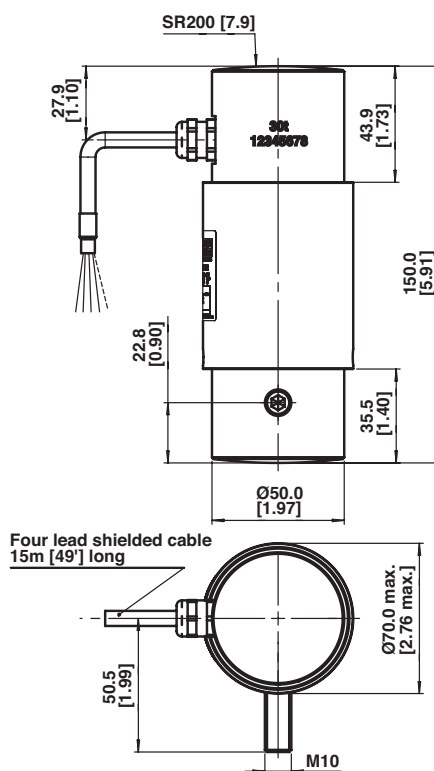

Rocker Column Load Cell

SPECIFICATIONS					
PARAMETER	VALUE				UNIT
Rated capacity—R.C. (E _{max})	30, 40				T
Accuracy class designation	Non-Approved	NTEP IIIIL	OIML C3	OIML C3MR	
Accuracy class	E	I3	G5	G3	
Minimum utilization	NA	33	50	30	% of R.C.
Maximum no. of intervals (n)	NA	10000 Mult	3000		
Rated output—R.O.	2.0				mV/V
Rated output tolerance	0.02				±mV/V
Zero balance	0.02				±mV/V
Creep, 30 min.	0.074	0.050	0.025		±% of load
Zero return, 30 min.	0.050	0.015	0.017		±% of load
Total error	0.060	0.03	0.020		±% of R.O.
Temperature effect on output	0.0023	0.0012	0.0012		±% of load/°C
Temperature effect on zero	0.0046	0.0014	0.0023	0.0014	±% of R.O./°C
Y = E _{max} /V _{min}	NA	30000	6000	10000	
Temperature range, compensated	-10 to +40				°C
Temperature range, safe	-30 to +70				°C
Temperature range, storage	-40 to +90				°C
Maximum safe static overload	150				% of R.C.
Ultimate static overload	300				% of R.C.
Excitation, recommended	10				VDC or VAC RMS
Excitation, range	5 to 20				VDC or VAC RMS
Input impedance	1160±60				Ω
Output impedance	1000±10				Ω
Insulation resistance	>2000				MΩ
Cable length	15				m
Cable type	4 conductors, AWG 24, PU jacket				
Color code	+Exc: Green, +Sig: White, -Exc: Black, -Sig: Red Shield: Bare, twisted braid				
Construction	Coated alloy steel, coated aluminum housing, environmental potting, quadruple o-ring seal				
Environmental protection	IP66/IP68—5 bar				

All specifications are subject to change without notice.