

## High Capacity Compression Load Cell

### FEATURES

- Capacities 3–50 t
- Stainless steel housing
- Surge arrestors fitted
- Simple to install
- 0.02% total error
- 6 wire sense circuit
- Output tolerance 0.1%

### APPLICATIONS

- Truck weighbridges
- Silo and hopper weighing
- Train “rail” scales
- Process weighing

### DESCRIPTION

The Model 120 is a high capacity truck scale and silo load cell which is supplied complete with its own unique rocker mounting components.

Suitable for all heavy duty weighing applications, the Model 120 gives the user high accuracy and low installation cost.



The Model 120 has a stainless steel housing to protect against corrosion. The alloy steel compression element is nickel-plated, and the rocker mounting accessories are zinc-plated alloy steel.

The two additional sense wires feed back the voltage reaching the load cell. Complete compensation of change in lead resistance, due to temperature change and/or cable extension, is achieved by feeding this voltage into the appropriate electronics.

### OUTLINE DIMENSIONS in millimeters

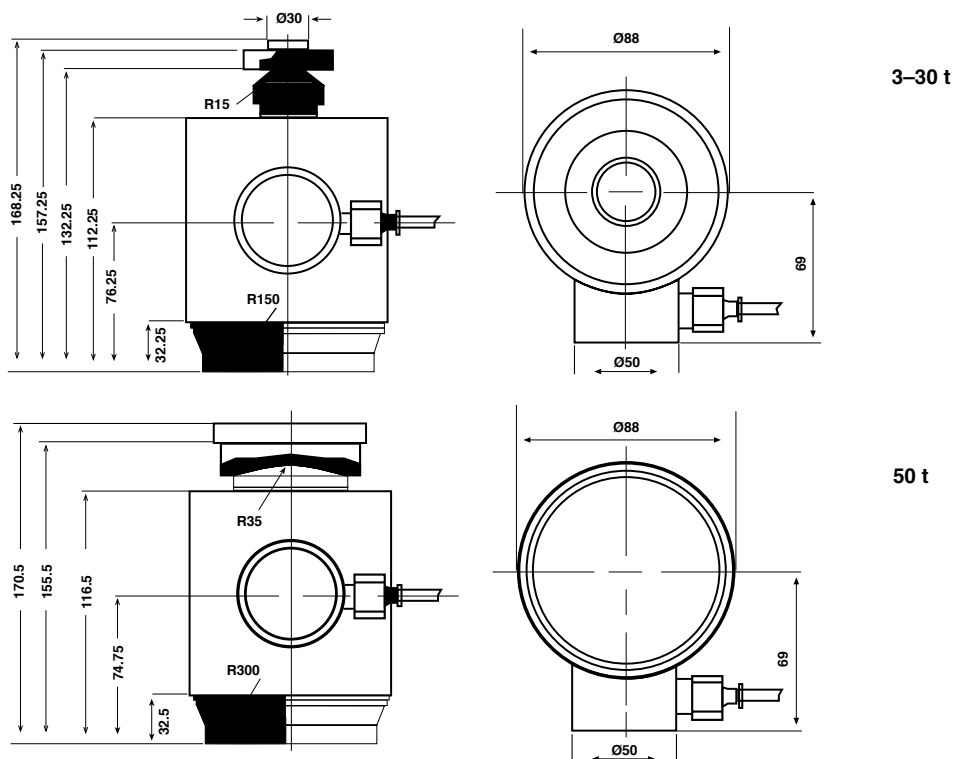

High Capacity Compression Load Cell

SPECIFICATIONS			
PARAMETER	VALUE		UNIT
Rated capacity—R.C. ( $E_{max}$ )	3, 5, 10, 20, 30, 50		t
NTEP/OIML accuracy class	Non-Approved*		
Maximum no. of intervals (n)	1000	3000	
$Y = E_{max}/V_{min}$	2000	6000	
Rated output—R.O.	1.5		mV/V
Rated output tolerance	0.0015		±mV/V
Zero balance	0.15		±mV/V
Zero return, 30 min.	0.0500	0.0200	±% of applied load
Total error (per OIML R60)	0.0500	0.0200	±% of rated output
Temperature effect on zero	0.0100	0.0040	±% of rated output/°C
Temperature range, compensated	-10 to +40		°C
Temperature range, safe	-30 to +70		°C
Maximum safe central overload	150		% of R.C.
Ultimate central overload	200		% of R.C.
Excitation, recommended	10		VDC or VAC RMS
Excitation, maximum	24		VDC or VAC RMS
Input impedance	670±15		Ω
Output impedance	605±5		Ω
Insulation resistance	>2000		MΩ
Cable length	15		m
Cable type	6-wire, braided, polyurethane, dual floating screen		Standard
Construction	Stainless steel housing, plated alloy steel element		
Environmental protection	IP68		

\* Typical 80% utilization

All specifications subject to change without notice.

**WIRING SCHEMATIC DIAGRAM**

